

REVISION HISTORY			
REV	DESCRIPTION	DATE	APPROVED
0	DRAWN ON CAD	01/18/12	

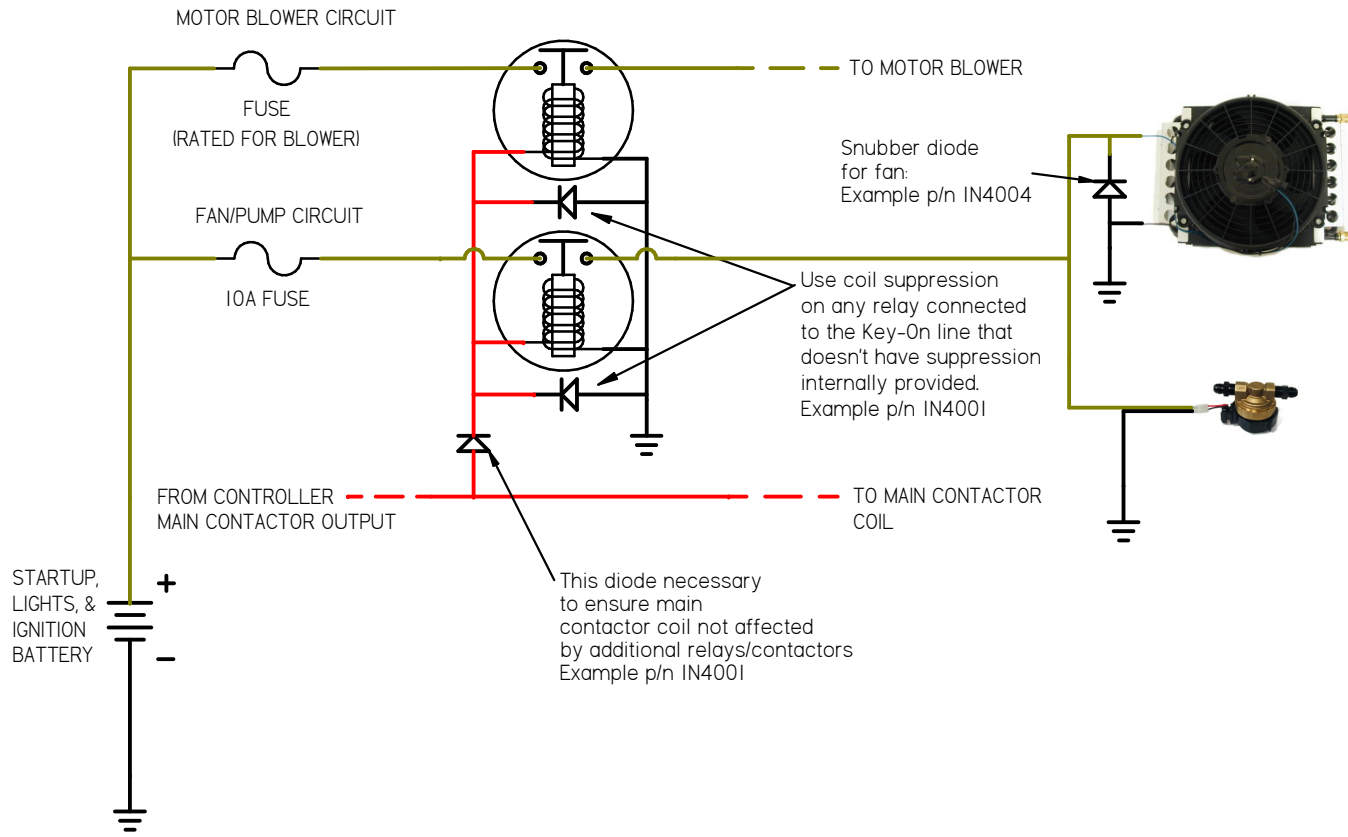

**NOTES:**

1. This diagram shows a simple method of switching additional loads such as liquid cooling components using the output from the main contactor driver from the controller. Ensure that the shown protection diodes are correctly in place.
2. ALL wiring downstream of fuses MUST be capable of handling the fuse rating current.
3. Motor blower initial circuitry shown for reference. Observe correct fuse rating and snubber circuitry for specific application.
4. This diagram is provided for reference only. Correct functionality and complete safety of the system is the responsibility of the installer.

NAME	DATE	NetGain Controls, Inc.	
DRAWN RYAN	01/23/12	TITLE	Example Wiring for Loads Such as Liquid Cooling, Switched By Main Contactor Coil Circuit
CHECKED		SIZE	A
PLOT DATE		REV	0
THIS DRAWING IS THE PROPERTY OF NETGAIN CONTROLS, INC AND IS NOT TO BE USED FOR ANY PURPOSE OTHER THAN THAT FOR WHICH IT WAS SPECIFICALLY FURNISHED		SCALE	WEIGHT: