

REVISION HISTORY			
REV	DESCRIPTION	DATE	APPROVED
0	DRAWN ON CAD	01/10/10	
1	ADDED FUSE RECOMMENDATIONS	04/20/10	
2	ADDED BRAKE/REV LIGHT INPUTS	08/25/10	
3	REVISED BRAKE/REV, ADDED DASH	01/11/12	

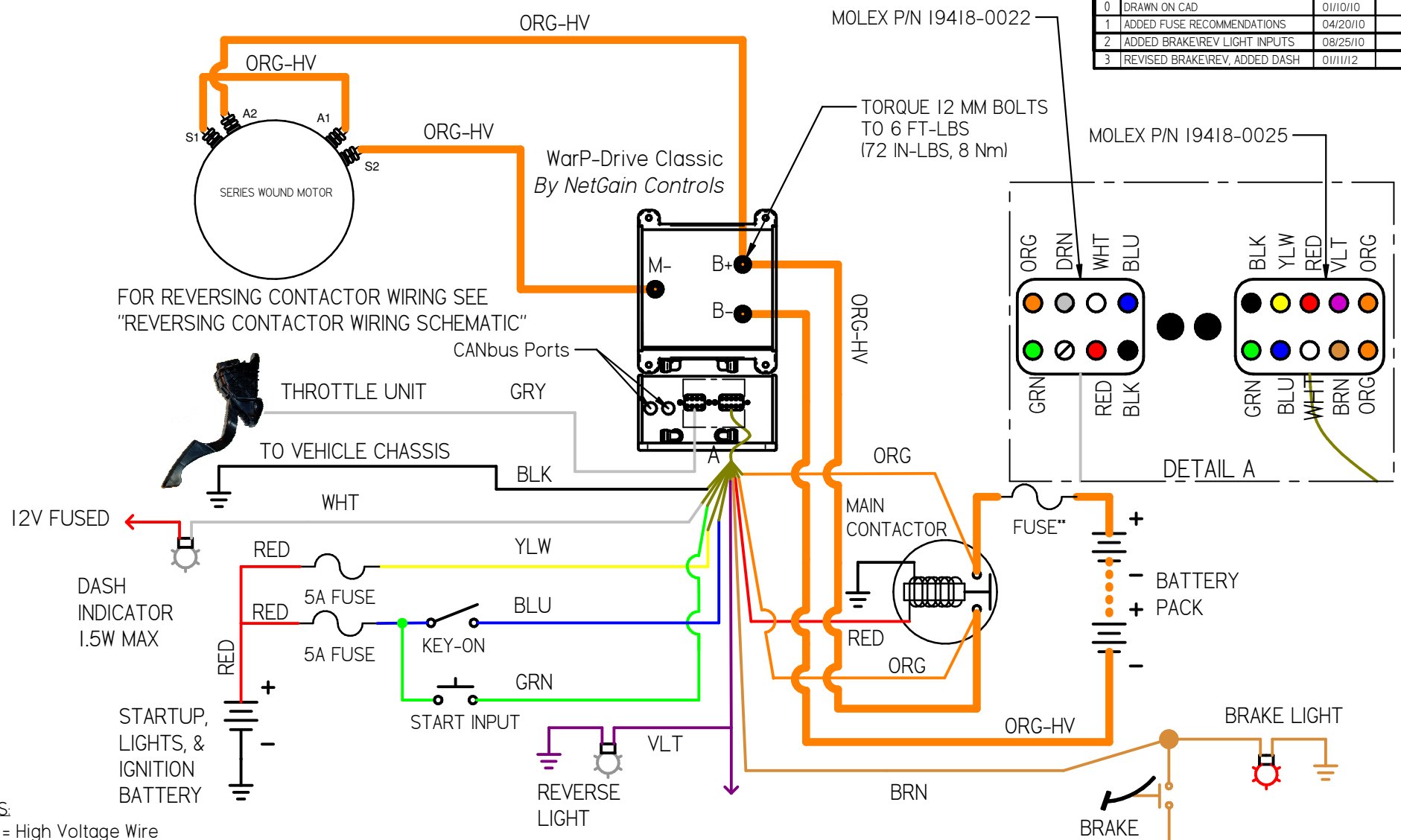

- NOTES:**
1. HV = High Voltage Wire
 2. Orange Wires on 10 pin connector are not polarity sensitive
 3. Motor Wiring is based on NetGain WarP series motors recommended connection method. For full documentation, visit www.go-ev.com
 4. Observe polarity for contactors with magnetic blowouts
- This diagram shows a minimal installation without additional safety precautions such as redundant contactors.
5. If adding loads in parallel w/ main contactor circuit, follow recommendations in diagram [acc_loads_by_main_contactor_circuit.pdf](#)

***Fuse Recommendations:**
 For 1000A, 160V or 260V controllers : Ferraz Shawmut part number A30QS500-4
 For 1200 or 1400A, 160V or 260V controllers: Ferraz Shawmut part number A30QS800-4
 For 1000A, 360V controllers : Ferraz Shawmut part number A50QS400-4
 For 1200 or 1400A, 360V controllers: Ferraz Shawmut part number A50QS700-4

NAME	DATE	NetGain Controls, Inc.	
DRAWN: BRYANT	09/28/10	TITLE: WarP-Drive Wiring Diagram	
CHECKED: RYAN		SIZE: A	
PLOT DATE: 01/23/12		REV: 3	
THIS DRAWING IS THE PROPERTY OF NETGAIN CONTROLS, INC AND IS NOT TO BE USED FOR ANY PURPOSE OTHER THAN THAT FOR WHICH IT WAS SPECIFICALLY FURNISHED		WDI_Wiring_Diagram_Basic.dft	
SCALE:	WEIGHT:		